

# R6VC Series D

Series D, Serial Numbers 236xxxx03 and up  
 Variable-Speed, 120 Volt, 1 Phase, 60Hz., 1 HP.  
 370-3450 RPM, 12 Amps  
 Use Series-D Plates.

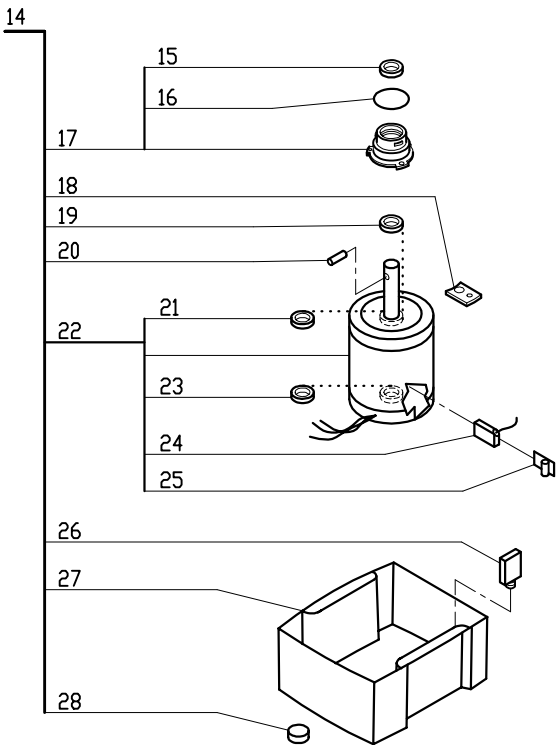
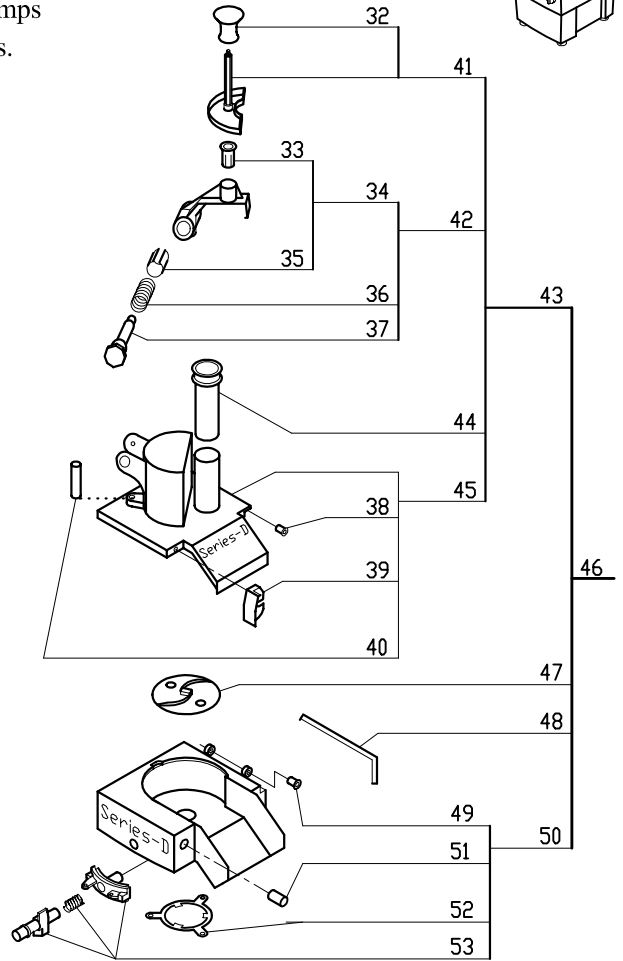
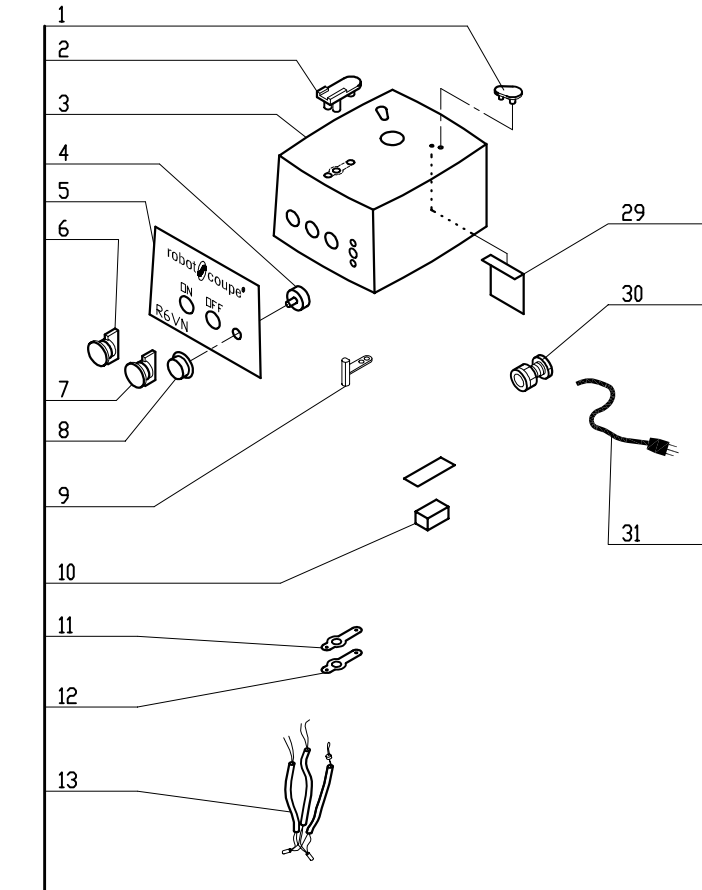
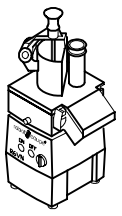

**ACCESSORIES**

Use only cutting plates listed on the "Series D" Chart.



## R6VC #3

INDEX	REF.	DESIGNATION	Pricelist in : USD
1	RA443	Pad,Rear	
2	RA441	Support/Pad,Front	
3	RA406	Motor Support	
4	RV6043	Speed Control Pot.	
5	407235	(D) Front Data Plate, R6VN	
6	RA418	Green "On" Switch Assy	
7	RA419	Red "Stop" Switch Assy	
8	RV614	Switch Knob	
9	102391	(D) Magnetic Switch R6VN Series D	
10	R664S	Relay DPST	
11	RA441.1	Gasket	
12	RA441.2	Metal Plate	
13	C420P	Mag Swtch w/Hse (2 prl)	
14	RVA699	R6VN Motor Base Assy	
15	R611	Motor Support Seal	
16	RA489	O Ring, Seal Support	
17	RA467	Seal Assembly (Seal Support)	
18	RA455	Plate, Motor Mounting	
19	R604S	Seal, Motor	
20	R492A	Shaft Pin (new style)	
21	R662	Bearing, Motor Top	
22	RVA604	Motor Only (New Style R6VN)	
23	R1540	Bearing (6206)	
24	RVA604.2	Brush	
25	RVA604.3	Spring, Brush	
26	RB497	15amp Breaker (CSA)	
27	RA493	Base	
28	RA402	Foot	
29	RV6041	PC Board W/Switch	
30	RA490	Strain Relief	
31	R496	Cord W/Plug (R4X,S,P,Y)	
32	R199	* Robo-Cart	
33	R255	* Plate Rack	
34	R475	* Plate Rack (Individual)	
35	CL575	* Plate Rack (wall mount)	
57	CL569	Pusher Knob	
58	CL588	Insert, Plastic	
59	29695	(D) Hinge Bracket	
60	100581	(K)Bushing for Spring	
61	100556	Description NA	
62	118374	(K)Pivot, Pusher Return Bracket	
63	CL523	Hinge Pin Bushing	
64	29501	(K)Lock for Feed Cover	
65	118377	(K)Extra Safety Rod	
66	CL576	Large Pusher Assembly	
67	29102	(D)Bracket-Pusher Return Assy	
68	29696	(D)Cont Feed Lead Assy W/Extra Safety	
69	118324	(L)Small Pusher	
70	127508	(D)Cont Feed Lead	
71	27199	* (D) Cont Feed Kit W/Extra Safety/R6	
72	102690	(K)Discharge Plate	
73	CL520	Hinge Pin	
74	CL523	Hinge Pin Bushing	
75	29697	(D)Cont Feed Bowl (R6 Series D)	
76	CL573	Stud Bolt, Latch	
77	118433	(D)Locking Collar	
78	28107	(D)Locking Pin Assy	